

Priority Switch Controller

FEATURES

- Automatic operation.
- Selection of main / reserve / standby priority.
- Local / remote control of all functions.
- Remote and local status information.
- Audio fail override facility using IRT AG-738 / AAD-4130 audio detector.
- May be used for audio only applications.

FRONT PANEL INDICATORS AND CONTROLS

- Fail LED's on the main, reserve and standby paths.
- Indication of the priority source selected.
- Indication of the ON AIR source.
- Auto/manual enable indication.
- Push buttons for priority selection of sources in auto mode and direct selection of manual mode.

GENERAL

The CDC-3062 is a video presence detector which also provides logic and switching control circuitry for interfacing to IRT 700, 3000 & 4000 series video and audio switchers.

The main use for the controller is to provide control of transmission link paths and to provide alarm and status information to centralised monitoring facilities.

The video signals of the *main*, *reserve* and *standby* paths are monitored, with an indication provided to show the loss of the input signal.

Any of the *main*, *reserve* or *standby* paths can be selected as the priority path and, provided a signal is present, this selection will be the ON AIR source.

If the priority selected path should fail the unit will provide control signals to select another input.

Where a failure occurs on *main*, *reserve* and *standby* inputs then the system will select the *local* input.

Once any input signal is restored the system will switch back from the *local* signal to an input signal, with the priority selected input having precedence when more than one input signal is available.

BLOCK DIAGRAM CDC-3062 SIGNAL PATH

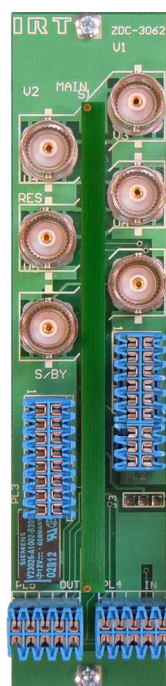
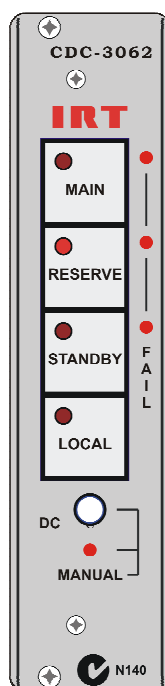
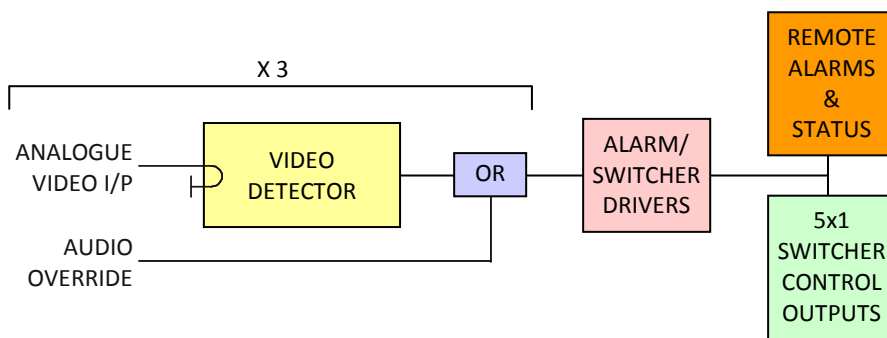

TECHNICAL SPECIFICATIONS

Inputs:

Video:

Type 3 x loop through.
Connector BNC.

Extended failure:

Type 3 x opto isolated failure override.

Control

Type 5 bit BCD coded parallel TTL level.
Number 1 "input" & 1 "output".
Connectors Plug in 10 pin dual IDC.

Manual override:

Type 1 x opto isolated manual / auto toggle.

Outputs:

IRT 3000 series interface As above.
IRT 700 series interface TTL level

Alarm tallies:

Function Auto mode enabled.
 Main present.
 Reserve present.
 Standby present.
 Main has priority.
 Reserve has priority.
 Standby has priority.
 * Main tally.
 * Reserve tally.
 * Standby tally.
 * Local tally.
 * Not available when using 700 series switchers.

Type TTL level or
 Open collector transistor 100 mA @ 30 Volts.

Power Requirements:

Voltage 28 Vac CT (14-0-14) or ± 16 Vdc.
Power consumption < 3 VA.

Other:

Temperature range 0 - 50° C ambient.
Mechanical Suitable for mounting in IRT 19" rack chassis with input output and power connections on the rear panel.
Finish **Front panel** Grey, black lettering & red IRT logo.
Rear assembly Detachable silk-screened PCB with direct mount connectors to Eurocard and external signals.
Dimensions 6 HP x 3 U x 220 mm IRT Eurocard.