

## 18 Channel CWDM Fibre Optic Multiplexer/Demultiplexer

### FEATURES

- Eighteen set CWDM optical wavelength inputs and outputs.
- Low insertion loss.
- Uni-directional or bi-directional operation.
- Connections made by LC/PC and SC/PC connectors.

### BLOCK DIAGRAM OFM-4218 SIGNAL PATH

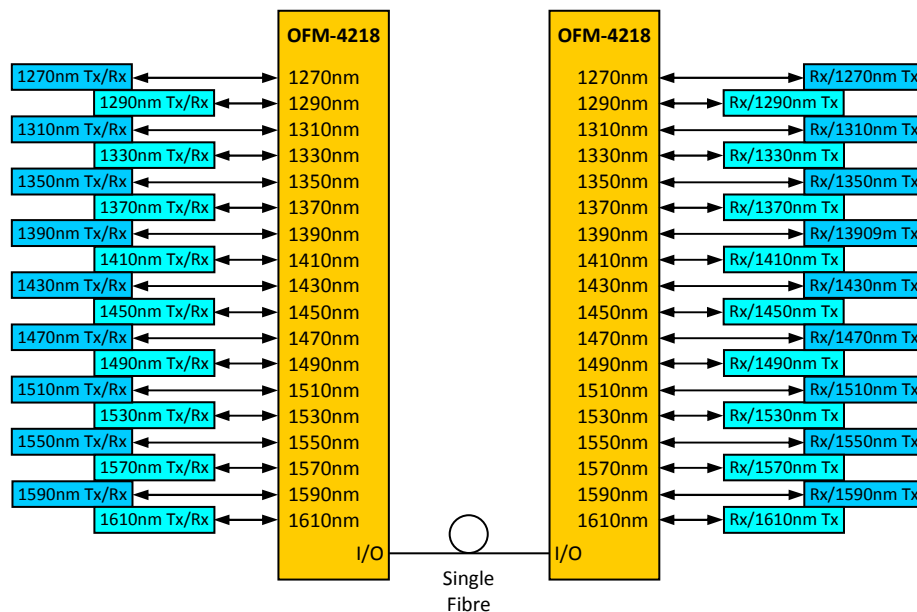

### GENERAL

The OFM-4218 is coarse wave division optical wavelength division multiplexer / demultiplexer (CWDM) for combining and separating up to eighteen optical signals of 1270nm, 1290nm, 1310nm, 1330nm, 1350nm, 1370nm, 1390nm, 1410nm, 1430nm, 1450nm, 1470nm, 1490nm, 1510nm, 1530nm, 1550nm, 1570nm, 1590nm and 1610nm wavelengths for either uni-directional or bi-directional transmission on the one fibre.

With the high cost of hiring or installing additional dark fibre it makes economical sense to maximise the use of existing infrastructure.

Used in combination with IRT's extensive range of fibre transmitters / receivers and interface modules, a myriad of different signals types can be sent down the one fibre. With IRT's eighteen channel fibre multiplexer/demultiplexer modules, for example, up to 144 SDI signals can be sent down a single fibre. Or up to 576 ASI signals can be sent when also used with IRT's ASI multiplexer/demultiplexer modules.

The OFM-4218 is designed to mount in IRT's 1RU or 4000 series 3RU frame.

### TECHNICAL SPECIFICATIONS

<b>Type</b>	18 Channel CWDM multiplexer.
<b>Wavelengths</b>	1270 nm, 1290 nm, 1310 nm, 1330 nm, 1350 nm, 1370 nm, 1390nm, 1410nm, 1430 nm, 1450 nm, 1470 nm, 1490 nm, 1510 nm, 1530 nm, 1550 nm, 1570 nm, 1590 nm and 1610 nm.
<b>Fibre</b>	Single mode.
<b>Connector Type</b>	18 x LC/PC; and 1 x SC/PC Common I/O.
<b>Maximum Power Handling</b>	500 mW.
<b>Channel Passband</b>	± 6.5 nm.
<b>Insertion loss</b>	≤ 3.2 dB.
<b>Passband Ripple</b>	< 0.3 dB.
<b>Return Loss</b>	> 45 dB (typically 50 dB).
<b>Directivity</b>	> 50 dB.
<b>Channel Isolation</b>	> 30 dB (typically 40 dB).
<b>Non Adjacent Channel Isolation</b>	> 40 dB (typically 50 dB).
<b>Polarization Dependent Loss</b>	< 0.2 dB.
<b>Other:</b>	
<b>Temperature range</b>	-10 - 70° C ambient.
<b>Mechanical</b>	Suitable for mounting in IRT 19" 1RU or 4000 series 3RU rack chassis with input and output connections on the rear panel.
<b>Finish</b>	Grey background, black lettering & red IRT logo.
<b>Front panel</b>	
<b>Rear assembly</b>	Common connection mounted on bracket from main PCB.
<b>Dimensions</b>	6 HP x 3 U x 220 mm IRT Eurocard.

